



MODELLING AND SIMULATION OF HYBRID WIND/PV STANDLONE GENERATION SYSTEM

Er. Manoj Lalotra¹, Er. Kiranjit Kaur² Department of Electrical Engineering, Desh Bhagat University, Mandi Gobindgarh, Punjab : Kiransimrat13@gmail.com

ABSTRACT: This work proposes a Wind/PV Standalone Generation System that solves the major problems of fuel and pollution. Renewable energy is vital for today's world as in the near future the nonrenewable sources that we are using are going to get exhausted. Power generated by renewable energy sources has recently become one of the most promising solutions for the electrification of islands and remote rural areas. However high dependency on weather conditions and the unpredictable nature of these renewable energy sources are the main drawbacks. To overcome this weakness, different green energy sources and power electronic converters need to be integrated with each other. The charged batteries are used to drive the motor which serves here as an engine and moves the vehicle in reverse or forward direction. This idea, in the future, may help to protect our fuels from getting extinguished. The results of the seasonal analysis showed how well the solar PV system generated electricity. Based on the system's performance study, the findings showed that the 600Wp solar system could, with the help of BESS, deliver intermittent power to the demand for electricity throughout the year.

Keywords: Greenhouse gas (GHG), Renewable Energy

1. Introduction: From a political, economic, and societal perspective, supplying sustainable energy has emerged as a major problem of the twenty-first century (Zandler et al., 2016). Because of greenhouse gas (GHG) emissions that are either directly or indirectly released into the atmosphere, the global energy industry (which includes transportation and electricity) has already had a significant negative impact on the environment. Global warming, climate change, environmental pollution, and restrictions on the conservation of natural resources are all caused by greenhouse gas (GHG) emissions (Jibrán and Mudassar, 2016; Kweku et al., 2017; Gwani and Abubakar, 2016). About 70% of the world's CO₂ emissions are attributed to the use of fossil fuels for energy-related purposes, making it one of the major offenders. Electricity, which is essential to the growth of any society, is already responsible for 37.5% of the world's CO₂ emissions, or 7700 million tonnes per year. This shows that a significant shift must be made in order to decarbonize electricity

globally (Moutinho and Robaina, 2016; Safari, 2011; Shata, 2012). One of the most often used sources of energy by people around the globe is electricity. More than 1.64 billion people worldwide, with a large portion residing in rural Africa and Asia, are completely without access to electricity, according to literature searches (Samsul Alam, 2018; Evangelos et al., 2016). Given the sizeable population who live without electricity, it is clear that access to electricity in some nations is more of a privilege than a basic human right.

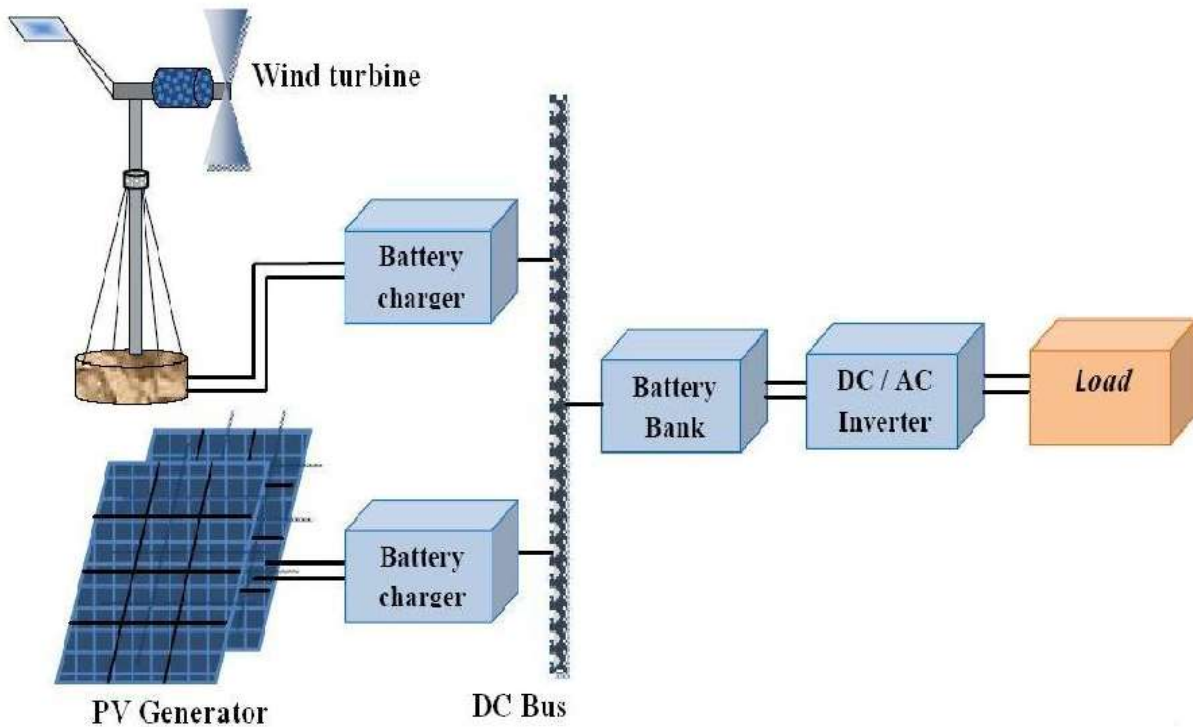

Fig. 1.1 HYBRID WIND/PV STANDLONE GENERATION SYSTEM

Surprisingly, the majority of people without electricity in the world live in low-income homes in rural communities where renewable energy resources are easily accessible and less expensive to explore than expanding the grid (Sampo et al., 2011; Dihrab and Sopian, 2010; Finnveden, 2009). Since prior centuries, the consequences of global warming and climatic change have been visible. Extreme weather events (hurricanes, tsunamis, and severe flooding), alterations in precipitation and seasonal patterns, sea-level rise, and an increase in the world's average temperature are only a few of the most compelling pieces of evidence. As a result of decreased heat demand and increased cooling demand, which are both carbon and energy-intensive processes, the average global temperature is rising, which

is a cause for concern on a global scale (Torben and Kallbekken, 2010; Semmaria et al., 2017). According to studies, 16,000 deaths each year are attributed to climate change and global warming, and if fossil fuels continue to be the world's major source of energy by the year 2020, this number is anticipated to more than double (Mendoza-Vizcaino et al., 2016; Eyad, 2009).

1.2 Renewable Energy in India

Being environmentally benign and economically viable power generation methods, renewable energy sources (RESs) are proving to be a more viable option for delivering sustainable energy services. In rural areas with limited grid power availability, RESs are especially important for addressing energy poverty (Blenkinsopp et al., 2013). Due to its numerous initiatives and carefully thought-out policies, India is among the nations with the highest amounts of energy produced from renewable sources when compared to other electricity-generating technologies.

One of the world's most comprehensive and ambitious RESs expansion capacity programs is being carried out in India. India is now the second-largest solar PV producer and the fourth-largest wind producer. India has already surpassed the United States, Japan, Germany, and Italy in the global ranking of top solar PV installed countries from 2017, as a result of the significant increase in solar PV installed power in 2018. India is the only Asian nation to rank among the top nations in the world for installed wind capacity, despite the fact that installed wind capacity has not expanded significantly outside of China. India is now the second-largest solar PV producer and the fourth-largest wind producer, as a result of the ambitious plans for the penetration of RESs in the nation.

India has already surpassed the United States, Japan, Germany, and Italy in the global ranking of top solar PV installed countries from 2017, as a result of the significant increase in solar PV installed power in 2018. India is the only Asian nation to rank among the top nations in the world for installed wind capacity, despite the fact that installed wind capacity has not expanded significantly outside of China. The data in the shows that, when micro renewable electricity generation technology is introduced, India has the potential of becoming the global leader in renewable energy production.

2.1 Literature Review

Sustainable electricity and transportation have become the grand challenges of the twenty- first century from the political, economic and societal point of view (Siva et al., 2018). Utilization of fossil fuels for transportation and energy-related issues is among the biggest source of anthropogenic carbon emission, accounting for about 60% of the global CO₂ emission. Electricity as the backbone of development of any society has already contributed 37.5% of the total CO₂ emission in the globe releasing 7700 million tonnes of CO₂ annually; this is an indication that serious transition is necessary for decarbonising electricity across the globe (Jules et al., 2018; Moutinho et al., 2016; Ahmed Shata,

2012; Safari, 2011). Considering the amount of CO₂ from the electricity sector, it is clear that, a sustainable electricity supply is the major challenge of the developed, developing and underdeveloped countries across the globe. Fortunately, several methods of decarbonising electricity generation are already identified in the global energy sector. Among the identified methods includes, the used of efficient fossil fuels electricity systems (CHP), conventional fossil fuel electricity generation technologies with carbon capture systems and the use of renewable energy technologies for small, medium and large scale electricity applications (Siva et al., 2018; Moutinho et al., 2016; Safari, 2011). Although it can be argued that, what happened to the intermittent nature of renewable energy sources in electricity generation since renewable energy sources depends upon the season of the year. This is the driving factor that makes the globe to look at the renewable electricity technologies as failing to be an everlasting solution to the energy supply and security across the globe. The simplest solution that could be adopted to solve the effect of intermittency of renewable energy sources in electricity generation in the real-time and simulation environments is to look at the generation at diurnal level i.e. the hourly level of generation and complimenting different renewable energy technologies in the form of hybrid (Krishan and Suhag, 2019).

To address the issue of renewable energy technologies intermittency in electricity generation, several research studies are conducted globally in evaluating the feasibility, viability, and performance of renewable energy systems in electricity generation. Hybrid renewable energy system such as wind-solar hybrid, are considered in the global renewable energy sector as among the most promising renewable electricity generation sources in the context of sustainability to the environment. This is because, in several case studies, nearly all the traditional intermittency issues of the standalone renewable electricity generation technologies are solved by coupling two or more renewable energy sources (Shuvankar et al., 2015). Hybrid renewable energy systems have been developed and practically proven to generate autonomous, stable and sustainable power for both on-grid and off-grid applications because it helps in ensuring that the energy feed into the grid is more steady than using standalone renewable electricity generation sources (Edmond et al., 2017, Camille et al., 2016; Urzúa et al., 2016).

3.1 METHODOLOGY

The Malabar region of Kerala, India's Central University of Kerala is situated at Periyar, a town close to Kasaragod. The Central University of Kerala is located between 12° 39' 13" North and 75° 09' 77" East. As seen in Fig. 3.1, the university is situated in the Western Ghats, a region known for its rich biodiversity, and shares a western boundary with the Arabian Sea. Given its coastal position, the entire Kasaragod district has a tropical monsoon climate according to the Köppen climatic classification.

Renewable energy resources are prevalent in the district. However, the district is experiencing a severe lack of electricity despite having access to numerous renewable energy sources. The district's per capita power usage is 335 units compared to the state average of 549 units since there is a severe lack of electricity that is much below the standard. The hard truth causing the district's overall backwardness is this severe lack of energy (ElectricalIndia, 2018).

Kerala, also known as "God's Own Country," is one of India's smaller states, with the 12th-highest population and the distinction of being the country's first fully electrified state (Deepak, 2018). Nevertheless, despite this accomplishment, homes in hilly and forested areas remain in doubt because they are distant sites where grid energy installation is highly improbable due to the topography. Kerala is blessed with an abundance of renewable energy resources that, when used to generate electricity, can meet the entire state's power needs in a clean, green, and sustainable manner (Deepak, 2018). Due to various pioneering and distinctly different initiatives in comparison to other Indian states, such as the 10,000 rooftop solar power program and floating solar power plants, Kerala state has already made significant strides in the field of solar energy. Despite the numerous renewable energy projects that the state government of Kerala has started, their success is not noticeable throughout the Kasaragod district because the immediate residents reject them and are unaware of the projects' potential to end the district's ongoing power crisis.



Figure 3.1 Geographic localization of Periyar, Kasaragod

3.2 Wind Speed Data Modelling

The 10 years' worth of data (2006–2016) used in this study are made up of several meteorological parameters stored as metadata. Converting the retrieved wind speed data from 10m to 15m height is the initial stage in this study's modelling of wind speed data. The next step is to scale and sort the data after it has been adjusted for the month of the year. After that, the modified wind speed data was transformed into an average day for each of the four seasons of the year (summer, winter, monsoon,

and post-monsoon). A number of studies have developed and used interaction scripts for data extraction, including those by Laudari et al. (2018), Orhan and Murat (2017), Sinha and Kandpal (1991), Yeliz et al. (2015), Fatma et al. (2016), and Ozay and Melih (2016).

3.3 HRES Components

Wind Energy Conversion systems (WECs)

For the purpose of potential research and validation, the Eco-Worthy 400W horizontal axis wind turbine technical specification was used to model the output of wind power. The Eco-Worthy Wind Energy Conversion System (WEC) can run at low wind speeds with great efficiency and lifespan, making it reliable for both on-grid and off-grid applications. It also has an effective rotor design.

Solar PV Modules

An indigenous solar PV module was adopted in this study to ensure maximum accuracy of the system during the modeling and real-time system validation. The specifications and parameters of the solar PV system at Standard Test Conditions (STC) are given.

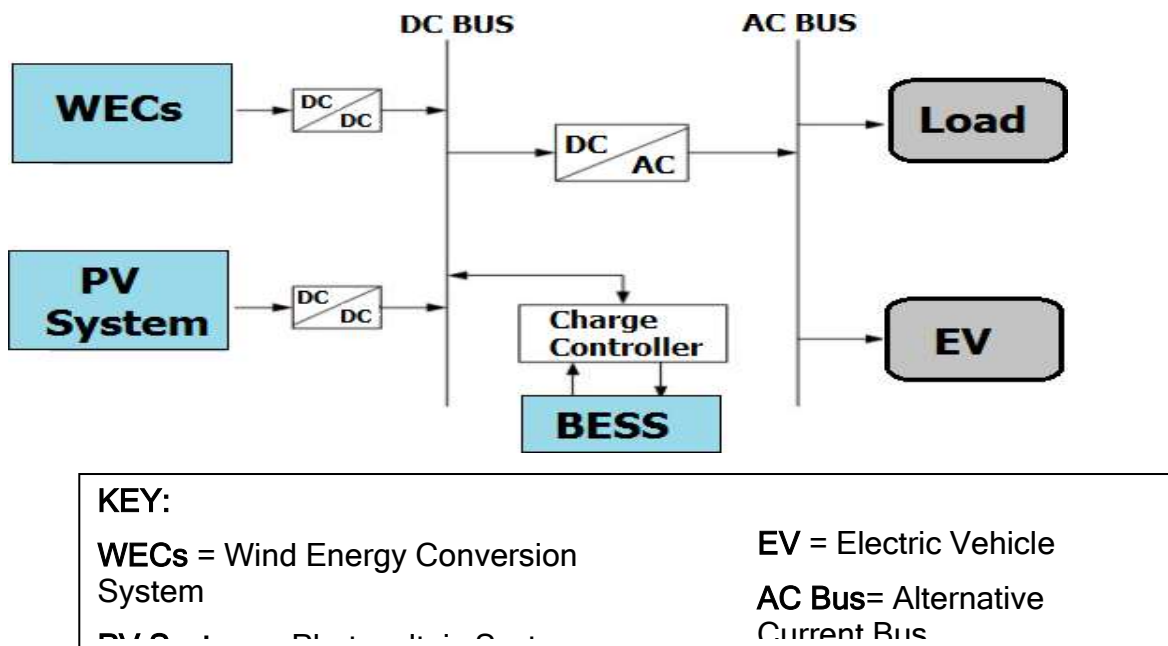

Figure 3.2 Hybrid system optimization

4.1 RESULTS AND DISCUSSION

The findings of the most thorough analysis of solar PV potential, based on the gathered data, were provided in this part. In order to offer a clear and accurate analysis of solar PV's role in energy generation at the study site, this part includes the findings of modeling, simulation, and validation studies that were carried out.

4.2 Monthly Solar Resources and Energy Generation

As is clearly shown in Fig. 4.1, the monthly irradiation ranges from 351.75 W/m² to 582.55 W/m², with an average value of 463.04 W/m². The maximum monthly irradiation, 582.55W/m², and the lowest, 351.75W/m², were both recorded in March. The findings of the study carried out by Ganesh and Ramachandra (2012) and Valsamma (2012) are comparable to the findings of the monthly irradiation described in this section. The research site's observed temperature ranges from 29.72°C to 26.28°C, with an average of 27.19°C. The maximum monthly average temperature of 29.72°C and the lowest figure of 26.28°C were both recorded in April. This demonstrates that the observed low temperature below the chosen PV module operating temperature will undoubtedly aid in maximising the output of the solar PV system all year long. According to the simulation of the monthly average energy generation shown in Fig. 4.2, the highest power output of 272.87W was produced in March, while the lowest insolation and power output of 164.76W were produced in June. The results of the monthly solar PV output showed how well the model was able to predict the power production of solar PV based on the data on irradiation that were available at each site of interest. The study by Ameer et al. (2019), Kittner, and others confirms that the higher irradiation values in March were the cause of the higher power output that was reported.

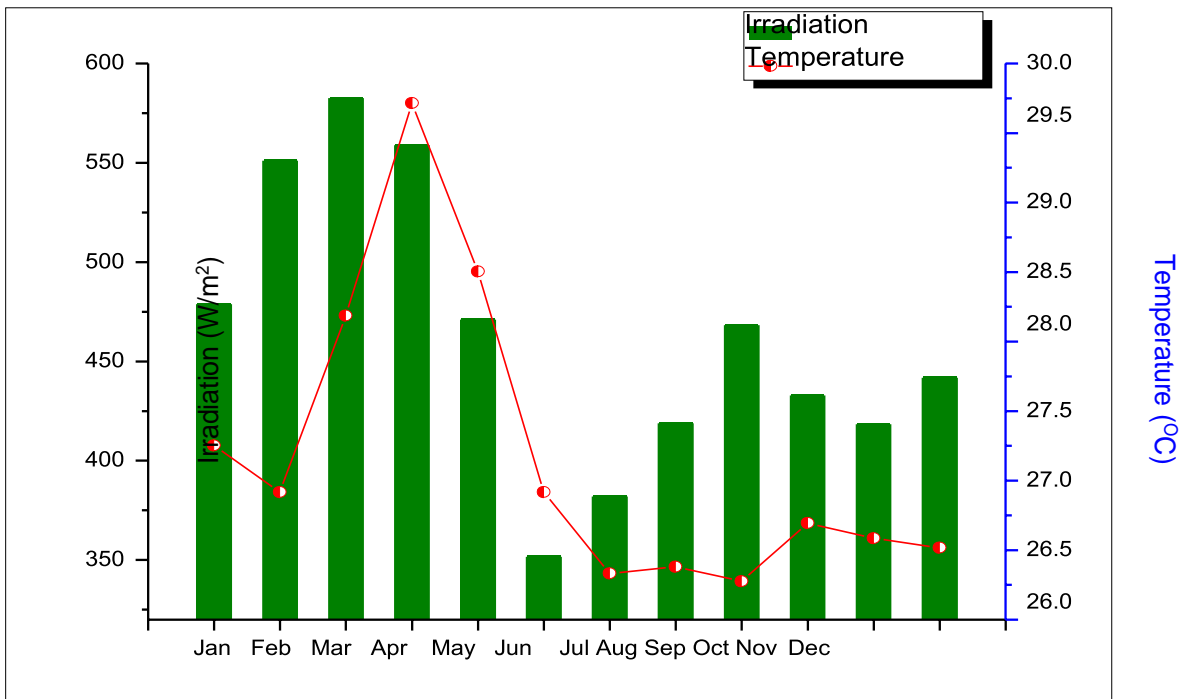
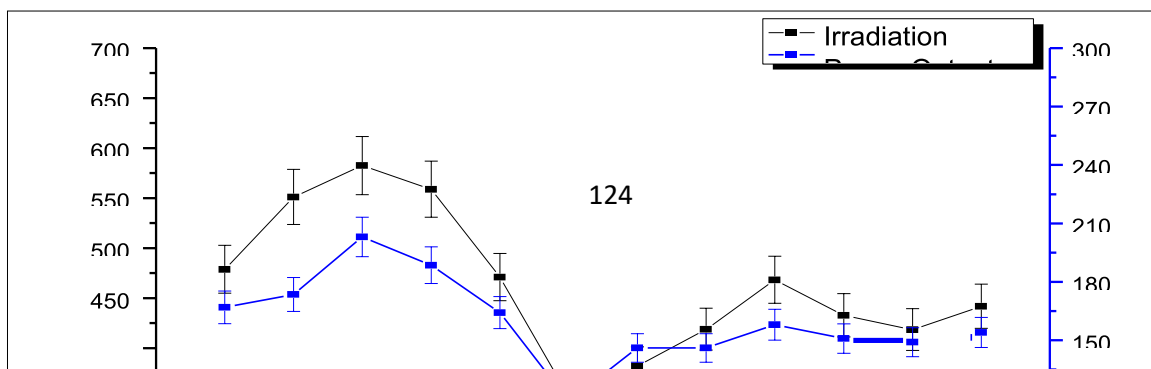

Figure 4.1 Global Horizontal Irradiation and Air Temperature at Central University of Kerala



Irradiation (W/m²)

Figure 4.2 Mean monthly irradiation and 600Wp solar PV performance at Central University of Kerala

4.3 Seasonal Variability and PV Potential

Planning any solar PV electricity generation system requires careful consideration of the seasonal variations of solar resources. At the site depicted in Fig the irradiation of a typical day during each season of the year clearly demonstrates a pattern of high values during the peak daylight hours. The data shown in the image made it evident that solar radiation reaches the surface of solar PV systems on average for 12 hours each day, with peak irradiation recorded during the peak sunshine hours throughout the year. The reason for the high irradiation values around midday is because the sun is at its highest position, which is when it shines directly down on Earth the most (Gerald, 2017; Chittari et al., 2013; Luhanga, 1995).

The simulation results of the 600Wp solar PV system are shown in Figure 4.3 for the seasons of winter, summer, monsoon, post-monsoon, and typical days. The peak power output produced by the solar PV system is 3.12kW in the summer, 2.8kW in the winter, 2.42kW in the monsoon season, and 2.40kW in the post-monsoon season, respectively. Additionally, during a normal day in all seasons, 2.81kW was noted. Additionally, during a normal day in all seasons, 2.81kW was noted. The data shows that the system's overall performance during the hours of sunlight is encouraging and can provide a good return on investment. A significant output was reported despite the monsoon season's continuous cloud cover, which is another intriguing finding that is clear from the results. This finding is crucial because it demonstrates the solar PV system's enormous potential to generate electricity throughout the research region.

When simulating solar PV systems, other meteorological factors like wind speed and ambient temperature are quite important. The average summer day recorded the greatest ambient temperature of 28.8°C, along with the highest solar PV performance and the highest irradiation levels. By applying 28.8°C can be converted to 48°C, which is within the NOCT (Nominal Operating Cell Temperature)

range for the chosen solar PV system. Additionally, a wind speed of 1 m/s is typically used in the NOCT calculations for solar PV systems. The investigation of the research site's wind speed data revealed an average wind speed of 3 m/s at a height of 10 m.

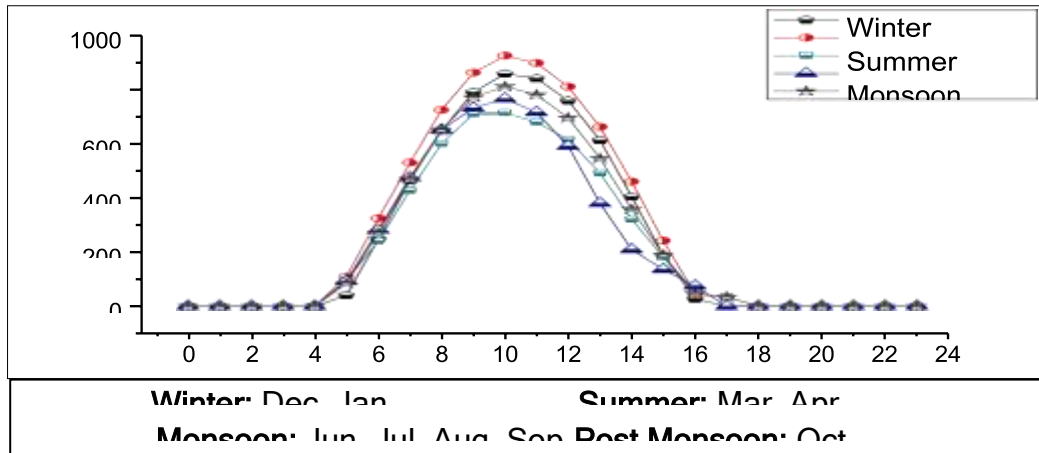

Figure 4.3 Diurnal insolation across the seasons of the year

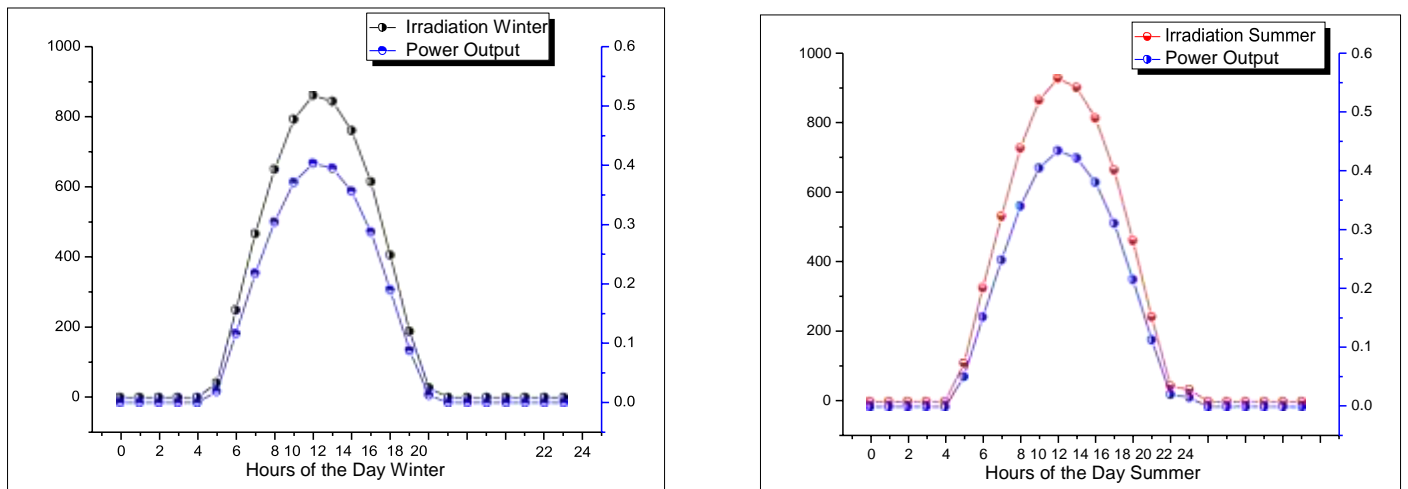

Figure 4.4 Diurnal irradiation and 600Wp performance at Central University of Kerala: a) Winter; b) Summer;

Hence, considering the cooling advantage of wind passing below the solar PV system, this will surely reduce the module operating temperature, which will help increase the performance of the PV system to a substantial level.

4.4 Diurnal Solar PV System Simulation and Demand Dynamics

The daily insolation and related air temperature at the study site are shown in Figure 4.5. It was evident that there is enough insolation at the site to facilitate solar PV electricity generation. The effectiveness of a solar PV system can be impacted by temperature as well as other meteorological factors like wind

speed and relative humidity, as was previously mentioned. The diurnal pattern of temperature showed that the early hours had a greater temperature. This is expected because humid regions typically experience greater diurnal temperature changes than desert ones, primarily due to the presence of major water bodies, different soil types, cloud cover, and ground moisture (Anie, 2018).

The typical household's hourly electricity usage is shown in Figure 4.5, along with the output of a 600Wp solar PV system. The chart provides evidence that during times of sunshine, solar PV system generation significantly outpaces the normal household electricity demand. It is also evident that if the Battery Energy Storage System (BESS) is coupled into the system architecture, there will be a gap between the generation and demand during non-sunny hours. With enormous spare power for other uses involving electricity, the BESS can fill the gap in the electricity demand when it is higher throughout the night and early morning hours. According to further study of the results, there is still an excess of 1.7kW, 2.1kW, 1.42kW, and 1.4kW during the winter, summer, monsoon, and post-monsoon seasons, respectively, even with BESS. In addition, an excess of 1.77kW more power is available throughout the study region on a normal day based on the electricity demand. The simulation findings showed the research area's solar PV electricity system to have enormous potential. The findings are consistent with research undertaken globally, as stated in studies by Gobind and Naser (2017), Dike et al. (2012), Marcel et al. (2007), and Harinarayana and Jaya Kashyap (2014

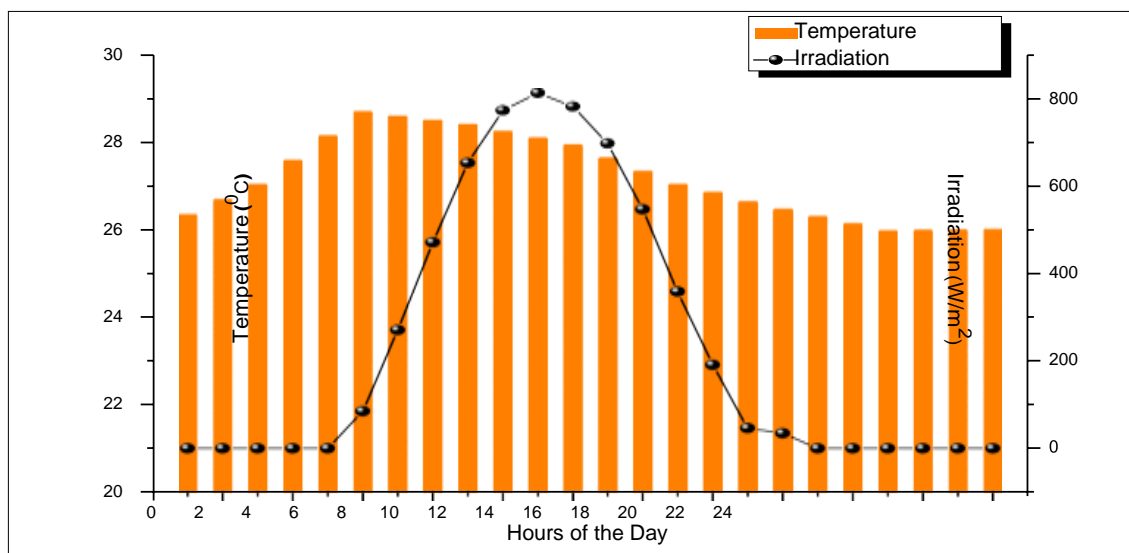

Figure 4.5 Diurnal solar radiation and corresponding air temperature across a typical day in all the seasons

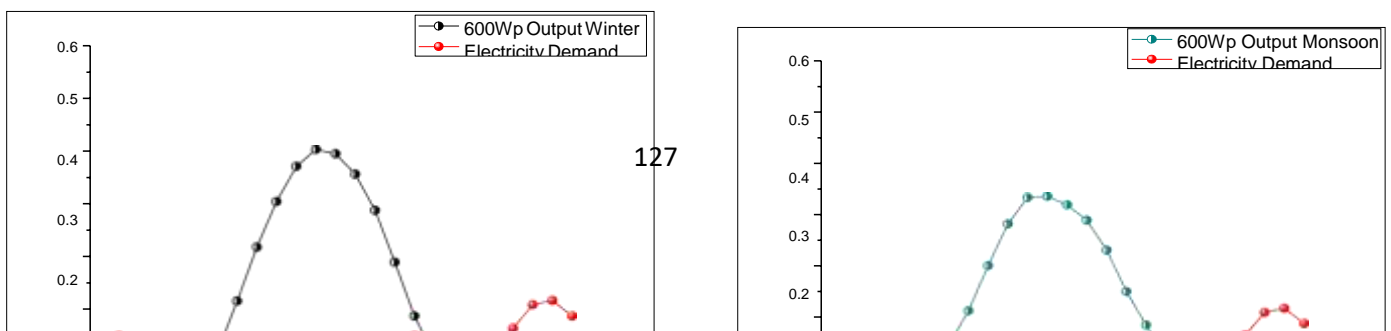

Figure 4.6 Typical household electricity demand against 600Wp PV system: a) Winter; b) Summer

The promise of satisfying energy demand for on-grid and off-grid applications, as well as application to EVs (Electric Vehicles), is made by renewable energy sources including wind, solar, small hydro, geothermal energy, etc. (Abdul Rauf et al., 2019). Although intermittent by nature, renewable energy sources can be used to generate electricity by looking at their potential at the diurnal level (i.e., the hourly level of generation) and by combining different renewable energy technologies into hybrid systems (Krishan and Suhag, 2019).

5.1 Conclusion

The findings of this study's innovative approach to evaluating, analysing, and validating a solar PV power system using a typical household electricity demand were given. The worldwide benchmark model for solar PV power output calculation was used to model the monthly and cyclical simulation of the solar PV system at the study location. The findings of the monthly analysis showed that the irradiation was highest in March and lowest in June. The system's overall diurnal study showed that a Battery Energy Storage System (BESS) is necessary for it to provide intermittent power. The results of the seasonal analysis showed how well the solar PV system generated electricity. Based on the system's performance study, the findings showed that the 600Wp solar system could, with the help of BESS, deliver intermittent power to the demand for electricity throughout the year.

The simulation results underwent validation in order to ensure experimental reproducibility and reliable scientific conclusions. The validation studies' findings showed that the simulation results are acceptable because they largely accord with the experimental findings. The chapter's conclusion is that all of the models used to determine the study site's potential for solar PV electricity generation are extremely flexible and may be used in any case study anywhere in the world.

The unique characteristics of wind and solar resources demonstrate that combining the two renewable energy sources to create a hybrid system can present a special potential for removing the intermittent nature of renewable energy sources in power generation. As is widely acknowledged, a simulated model's anticipated performance frequently outperforms that of a genuine hybrid plant, but this was not the case with this study's findings. In comparison to the predicted values, higher values were achieved on the experimentally observed values. The simulation and validation findings of the HRES

all showed that the system was capable of supplying the 800W electricity demand of the BSC-P1 electric campus shuttle in addition to the entire electricity requirement of a typical family.

REFERENCES

1. Abdul Rauf Bhatti, Zainal Salam, Beenish Sultana, Nadia Rasheed, Ahmed Bilal Awan, Umbrin Sultana, Muhammad Younas. (2019). Optimized sizing of photovoltaic grid-connected electric vehicle charging system using particle swarm optimization. *International Journal of Energy Research*, 43(1), 500-522.
2. Abhishek Tiwary, Stanislava Spasova, Ian D. Williams. (2019). A community-scale hybrid energy system integrating biomass for localised solid waste and renewable energy solution: Evaluations in UK and Bulgaria. *Renewable Energy*, 139, 960-967.
3. Adesanya, Adewale Aremu and Schelly, Chelsea. (2019). Solar PV-diesel hybrid systems for the Nigerian private sector: An impact assessment. *Energy Policy*, 132, 196-207.
4. Agustinus Ribal and Ian R. Young. (2019). 33 years of globally calibrated wave height and wind speed data based on altimeter observations. *Scientific Data*, 6, 77.
5. Ahammed, F. and Taufiq, D. A. (2008). Applications of solar PV on rural development in Bangladesh. *Journal of Rural and Community Development*, 3(1), 93-103.
6. Ahmed Shata Ahmed. (2011). Investigation of wind characteristics and wind energy potential at Ras Ghareb, Egypt. *Renewable and Sustainable Energy Reviews*, 15, 2750-2755.
7. Ahmed Shata Ahmed. (2012). Potential wind power generation in South Egypt. *Renewable and Sustainable Energy Reviews*, 16, 1528-15.
8. Akintayo Temiloluwa Abolude and Wen Zhou. (2018). Assessment and Performance Evaluation of a Wind Turbine Power Output. *Energies*, 11, 1992.
9. Alan, L and McGregor, J. (2008). Seasonal variation of the prevailing wind direction in Britain. *Weather*, 63(12), 365-368
10. Al-Ashwal, A. M, Moghram, I. S. (1997). Proportion assessment of combined PV/ wind generating systems. *Renewable Energy*, 10(1), 43-51.
11. Alex Zahnd, Angel Clark, Wendy Cheung, Linda Zou, Jan Kleissl, 2014. Minimizing the Lead- Acid Battery Bank Capacity through a Solar PV - Wind Turbine Hybrid System for a high- altitude village in the Nepal Himalayas. *Energy Procedia*, 57, pp. 1516-1525.
12. Al-Yahyai Sultan, Yassine Charabi, Adel Gastli, Saleh Al-Alawi. (2010). Assessment of wind energy potential locations in Oman using data from existing weather stations.

